

(0.36); and for three  $\pi$  donors,  $\text{BF}_2\text{NH}_2$  (0.39). Increasing the basis set size by 50% to the 6-311\*\* level gives a slight increase in the B  $2p_z$  population ( $\text{BH}_2\text{NH}_2$  (0.26) and  $\text{BH}(\text{NH}_2)_2$  (0.41)), indicating that the populations are not strongly dependent on basis set size. These results show that the capacity (per substituent) of the B  $2p_z$  orbital to accept electrons is reduced as more  $\pi$  donors are added to the borane center. This has important implications in terms of the dipole moments of boranamines. With the limited capacity of the B  $2p_z$  orbital to accept electrons, adding a  $\text{NH}_2$  group to  $\text{BH}_2\text{NH}_2$  polarizes the B-N bond more in the direction of  $^-\text{N}-\text{B}^+$ . This results from the addition of a center that withdraws electrons through the  $\sigma$  system, but which is less able to donate electrons to the already "saturated" B  $2p_z$ . If the B-N bond in  $\text{BH}_2\text{NH}_2$  is already polarized in the direction  $^-\text{N}-\text{B}^+$ , then  $\text{BH}(\text{NH}_2)_2$  should have a dipole moment larger than  $\text{BH}_2\text{NH}_2$ . If the B-N bond in  $\text{BH}_2\text{NH}_2$  is polarized  $^-\text{B}-\text{N}^+$ , then  $\text{BH}(\text{NH}_2)_2$  should have the smaller dipole moment. Since the experimental data show that the dipole moment of  $\text{BH}_2\text{NH}_2$  is greater than that of  $\text{BH}(\text{NH}_2)_2$ , the B-N polarization and molecular dipole moment must be polarized  $^-\text{B}-\text{N}^+$  in both molecules. These conclusions are consistent with Binkley's ab initio results<sup>5</sup> for the molecular dipole moments of  $\text{BF}_2\text{NH}_2$ ,  $\text{BH}_2\text{NH}_2$ , and  $\text{BH}(\text{NH}_2)_2$ , which are all in the direction  $^-\text{B}-\text{N}^+$ .

The B-N bond lengths can be rationalized on a similar basis. When additional  $\pi$  donors are substituted on B in  $\text{BH}_2\text{NH}_2$ , the B-N bond is expected to get longer since the additional electron density competes with the N lone-pair electrons for the limited  $\pi$ -accepting capacity of the B  $2p_z$ . This expectation is confirmed by the measured B-N bond lengths for  $\text{BH}_2\text{NH}_2$  (1.391 Å),<sup>9</sup>  $\text{BF}_2\text{NH}_2$  (1.402 Å),<sup>29</sup> and  $\text{BH}(\text{NH}_2)_2$  (1.418 Å). As indicated by the B  $2p_z$  populations for  $\text{BHF}_2$  and  $\text{BH}(\text{NH}_2)_2$ , N is a better  $\pi$  donor to B than is F.

Although rotational constants were not determined for the vibrational satellites, the vibrational mode responsible for the satellites can be tentatively assigned with the aid of results from the normal coordinate analysis<sup>22</sup> of boranediamine and symmetry considerations. First, the satellites must originate from excitation of a vibrational mode that has even parity with respect to a  $C_2$  rotation about the symmetry axis ( $b$  axis). This must be so because the hyperfine line shape for a particular ground-state transition

and its corresponding satellite is the same. This requires the ratio of the statistical weight factors for even and odd parity hyperfine components to be the same, both in the ground state and vibrational satellite transitions. For molecules having  $C_{2v}$  symmetry, this occurs only if the excited vibrational mode has even parity with respect to  $C_2$ . This eliminates  $B_1$ - and  $B_2$ -type modes from consideration. Thus, the remaining possibilities are low-frequency vibrations of  $A_1$  or  $A_2$  type. The two  $A_2$ -type modes involve principally out-of-plane motion of the amine hydrogens, while the lowest  $A_1$  mode, 402  $\text{cm}^{-1}$ , is the NBN angle deformation mode. Of these modes the NBN angle deformation mode is most likely to give the observed large frequency separation between the ground state and satellite transitions because it involves primarily motion of the heavy atoms, resulting in a large change in the A rotational constant. We conclude, therefore, that the vibrational satellites are due to the NBN angle deformation mode. Unfortunately, data taken for the temperature dependence of the satellite intensities were not sufficiently accurate to distinguish absolutely between the  $A_1$  mode at 402  $\text{cm}^{-1}$  and the  $A_2$  mode at 464  $\text{cm}^{-1}$ .

In answer to the question posed in the introduction, we find that delocalization of the nitrogen lone-pair electrons into the vacant boron  $2p_z$  orbital is sufficient to increase the B-N bond strength and cause the molecule to be planar. This is somewhat surprising in light of the ab initio results, which show the Mulliken population of the boron  $2p_z$  to be only  $\sim 0.3$  electron.<sup>2,3</sup> Clearly, extensive delocalization is not required to produce dramatic structural effects.

**Acknowledgment.** We acknowledge the financial support of the National Science Foundation. We thank A. S. Gaylord and D. C. Reuter for many helpful discussions and J. S. Binkley for performing many of the molecular orbital calculations to which we refer.

**Note Added in Proof.** The authors of ref 2 have reexamined their dipole moment calculations and now give the direction  $^-\text{BH}(\text{NH}_2)_2^+$ , in agreement with our results.

**Registry No.**  $\text{BH}(\text{NH}_2)_2$ , 18447-53-5;  $^{11}\text{BH}(\text{NH}_2)_2$ , 68963-53-1;  $^{11}\text{BHNDHND}_2$ , 81770-06-1;  $\text{BH}(\text{ND}_2)_2$ , 81770-07-2;  $^{11}\text{BH}(\text{ND}_2)_2$ , 81790-07-0;  $\text{BD}(\text{ND}_2)_2$ , 81770-08-3;  $^{11}\text{BD}(\text{ND}_2)_2$ , 68963-55-3.

## Electronic Structure of the Carbyne C-Li and the Carbene $\text{Li}_2\text{C}^\dagger$

Aristides Mavridis<sup>1</sup> and James F. Harrison\*<sup>2</sup>

Contribution from the Chemistry Department, Michigan State University, East Lansing, Michigan 48824, and the Theoretical Chemistry Group, Chemistry Division, Argonne National Laboratory, Argonne, Illinois 60439. Received August 7, 1981

**Abstract:** We have studied the electronic structure of the carbyne C-Li and the carbene  $\text{Li}_2\text{C}$  using ab initio GVB, SCF, and CI techniques. We find that C-Li has a  $^4\Sigma^-$  ground state with the companion  $^2\Pi_r$  state approximately 34 kcal/mol higher in energy. This should be contrasted with C-H in which the  $^2\Pi_r$  is the ground state and the  $^4\Sigma^-$  state is approximately 17 kcal/mol higher. In addition we find a  $^2\Pi_r$  state some 49 kcal/mol above the ground  $^4\Sigma^-$  state. An analysis of the bonding indicates that these states are highly polar.  $\text{Li}_2\text{C}$  is an unusual carbene having three triplets below the first singlet:  $^3\Sigma_g^-$ ,  $R = 3.717$  bohrs;  $^3\Pi_g(3)$ ,  $R = 3.507$  bohrs;  $^3A_2$ ,  $\theta = 88.1^\circ$ ,  $R = 3.815$  bohrs. At the SCF+1+2 level the  $^3\Sigma_g^-$  is the ground state with the  $^3A_2$  6.2 kcal/mol higher. Correcting for unlinked clusters inverts this order and makes the  $^3A_2$  the ground state 0.2 kcal/mol below the  $^3\Sigma_g^-$  state. An analysis of the bonding in the  $^3A_2$  states reveals a dative bond between the doubly occupied  $\text{Li}_2 2\sigma_g$  orbital and an empty  $p\sigma$  orbital on C. The implications of this mode of bonding for the dilithiomethanes are discussed.

In spite of their intrinsic interest, potential importance as organometallic fragments and obvious relation with CH,  $\text{CH}_2$ , and the lithiated hydrocarbon  $\text{H}_2\text{CLi}_2$ , lithium carbyne, C-Li, and dilithium carbene,  $\text{Li}_2\text{C}$ , have received very little attention in the

literature.<sup>3</sup> Our intent in this study is to use ab initio theoretical techniques to characterize the geometry and relative energies of

(1) On leave from the Chemistry Department, University of Athens, Athens, Greece.

(2) Scientist in Residence, Argonne National Laboratory, 1980/1981. To whom correspondence should be addressed at the Department of Chemistry, Michigan State University, East Lansing, MI 48824.

\* Work supported by the Office of Basic Energy Sciences, Division of Chemical Sciences, U.S. Department of Energy, under Contract W-31-109-Eng-38.

**Table I.** Optimized Exponents for the Carbon Diffuse p and d Orbitals and the Optimized Scale Factor for the Lithium p Orbital in Various Linear Triplet States of Li-C-Li<sup>a</sup>

state	R, bohrs	$\alpha_{cp}$	$\alpha_{cd}$	$\xi_{Li p}$	energy, hartrees	-V/T
$^3\Sigma_g^-$	3.670	0.03	0.50	1.55	-52.624 028	2.000 96
$^3\Pi_g(3)$	3.480	0.03	0.50	1.50	-52.598 758	2.001 02
$^3\Pi_u(1)$	3.914	0.17	0.50	1.80	-52.579 430	1.999 43
$^3\Pi_g(1)$	3.937	0.03	0.30	1.80	-52.572 260	2.000.03

<sup>a</sup> The optimization was carried out at the restricted open-shell SCF level.

the low-lying quartet and doublet states of C-Li and the low-lying single and triplet states of Li<sub>2</sub>C and to identify the differences between these molecules and the parent carbyne C-H and the parent carbene CH<sub>2</sub>. We believe this will clarify the effects of substitutions on the singlet-triplet splitting and provide necessary data for the interpretation of the novel structures recently predicted<sup>4-7</sup> for several lithiated hydrocarbons.

### Expansion Basis

We began our construction of an expansion basis with an 11s,6p set on carbon and a 9s set on Li, both from the compilation of Duijneveldt.<sup>8</sup> These were contracted to 5s,3p and 3s following Raffanetti.<sup>9</sup> We then augmented this basis with an additional one component p and d set on carbon and a contracted four-component 2p on lithium.<sup>10</sup> The exponents of the additional carbon p and d functions as well as the scale factor for the lithium p orbital were optimized in a series of SCF calculations on various triplet states of linear Li<sub>2</sub>C and are reported in Table I. All subsequent calculations will use the exponents determined for the  $^3\Sigma_g^-$  state. The final expansion basis was obtained by adding an additional s function with exponent 0.03 to the carbon atom resulting in a total of 24 contracted functions on carbon (6s,4p,1d) and 6 on lithium (3s,1p). The total SCF energies (in hartrees) for carbon and lithium calculated in this basis are as follows: C(<sup>3</sup>P), -37.688 07; C(<sup>1</sup>D), -37.630 77; Li(<sup>2</sup>S), -7.432 41; Li(<sup>2</sup>P), -7.364 57.

### Molecular Codes

The triplet SCF wave functions were constructed at Michigan State University by using Raffanetti's integral program, BIGGMOLI,<sup>11</sup> and the SCF routines from POLYATOM.<sup>12</sup> All other calculations were carried out at Argonne National Laboratory by using the collection of codes maintained by the Theoretical Chemistry Group. In particular, the integral evaluation and transformations were carried out with the programs BIGGMOLI<sup>9</sup> and TRAOMO written by R. C. Raffanetti. The GVB wave functions were constructed with the program GVB TWO, originally written by F. Bobrowicz and W. Wadt with latter modifications by L. G. Yaffe, A. K. Rappe, and others. The configuration lists for the CI calculations were generated by the program CIGEN written by B. D. Olafson and R. C. Ladmir with modifications by L. B. Harding. The CI calculations were carried out by using the program CITWO written by F. Bobrowicz with extensive modifications by S. P. Walch. The contour plots were generated by using a version of the CALTECH program CONTURM as modified

(3) (a) Harrison, J. F.; Liedtke, R. C.; Liebman, J. F. *J. Am. Chem. Soc.* **1979**, *101*, 7162. (b) Schoeller, W. W. *J. Chem. Soc., Chem. Commun.* **1980**, 124. (c) Pauling, L. *Ibid.* **1980**, 688. (d) Cade, P. E.; Huo, W. M. *At. Data Nucl. Data Tables* **1975**, *15*, 1.

(4) Collins, J. B.; Dill, J. D.; Jemmis, E. D.; Apeloig, Y.; Schleyer, P. R.; Seeger, R.; Pople, J. A. *J. Am. Chem. Soc.* **1976**, *98*, 5419.

(5) Apeloig, Y.; Schleyer, P. R.; Binkley, J. S.; Pople, J. A. *J. Am. Chem. Soc.* **1976**, *98*, 4332.

(6) Laidig, W. D.; Schaefer, H. F., III *J. Am. Chem. Soc.* **1978**, *100*, 5972.

(7) Laidig, W. D.; Schaefer, H. F., III *J. Am. Chem. Soc.* **1979**, *101*, 7184.

(8) Duijneveldt, F. B. IBM Technical Research Report No. RJ-945, 1971.

(9) Raffanetti, R. C. *J. Chem. Phys.* **1973**, *58*, 4452.

(10) Williams, J. E., Jr.; Streitwieser, A., Jr. *Chem. Phys. Lett.* **1974**, *25*, 507.

(11) Raffanetti, R. C. BIGGMOLI, Program 328, Quantum Chemistry Program Exchange, Indiana University.

(12) Neumann, D. B.; Basch, H.; Kornegoy, R. L.; Synder, L. C.; Moskowitz, J. W.; Hornback, C.; Liebmann, S. P. POLYATOM (Version 2), Program 199, Quantum Chemistry Program Exchange, Indiana University.

**Table II.** Electronic Configurations of the Six Lowest States of C-Li and Their Dissociation Limits<sup>a</sup>

configuratn	state	dissociatn limit
$1\sigma^2 2\sigma^2 3\sigma^2 4\sigma^2 1\pi^1$	$^2\Pi(1)$	C( <sup>3</sup> P) + Li( <sup>2</sup> S)
$1\sigma^2 2\sigma^2 3\sigma^2 4\sigma^1 1\pi^2 (^3\Sigma^-)$	$^4\Sigma^-$	C( <sup>3</sup> P) + Li( <sup>2</sup> S)
$1\sigma^2 2\sigma^2 3\sigma^2 4\sigma^1 1\pi^2 (^1\Delta)$	$^2\Delta$	C( <sup>1</sup> D) + Li( <sup>2</sup> S)
$1\sigma^2 2\sigma^2 3\sigma^2 4\sigma^1 1\pi^2 (^3\Sigma^-)$	$^2\Sigma^-$	C( <sup>3</sup> P) + Li( <sup>2</sup> S)
$1\sigma^2 2\sigma^2 3\sigma^2 4\sigma^1 1\pi^2 (^1\Sigma^+)$	$^2\Sigma^+$	C( <sup>1</sup> D) + Li( <sup>2</sup> S)
$1\sigma^2 2\sigma^2 3\sigma^2 1\pi^3$	$^2\Pi(3)$	C( <sup>3</sup> P) + Li( <sup>2</sup> P)

<sup>a</sup> Symmetries in parentheses give the coupling of the  $\pi^2$  configurations.

**Table III.** Bond Lengths and Absolute Energies of the Six Lowest Electronic States of C-Li As Predicted by the SCF+1+2 Calculations<sup>a</sup>

state	R, bohrs	abs energy, hartrees		rel energy, kcal/mol	
		SCF+1+2	$\Delta E_Q$	$\Delta(\text{SCF}+1+2)$	with $\Delta E_Q$
$^3P + ^2P$	$\infty$	-45.133 663	-0.0041	42.6	42.6
$^1D + ^2S$	$\infty$	-45.147 249	-0.0042	34.0	34.0
$^2\Pi(3)$	3.436	-45.197 869	-0.0153	2.3	-4.7
$^2\Sigma^+$	3.622	-45.198 590	<i>b</i>	1.8	<i>b</i>
$^3P + ^2S$	$\infty$	-45.201 510	-0.0041	0.0	0.0
$^2\Sigma^-$	3.687	-45.217 436	-0.0066	-10.0	-11.6
$^2\Delta$	3.618	-45.223 441	-0.0064	-13.8	-15.2
$^2\Pi(1)$	3.971	-45.226 883	-0.0097	-15.9	-19.4
$^4\Sigma^-$	3.598	-45.286 119	-0.0050	-53.1	-53.6

<sup>a</sup> The absolute energy of the relevant dissociation limits as well as the Davidson energy are also included. <sup>b</sup> The SCF+1+2 calculations for this state were done with the  $^2\Delta(+)$  vectors, and we do not have an SCF reference energy with which to calculate the Davidson correction,  $\Delta E_Q$ .

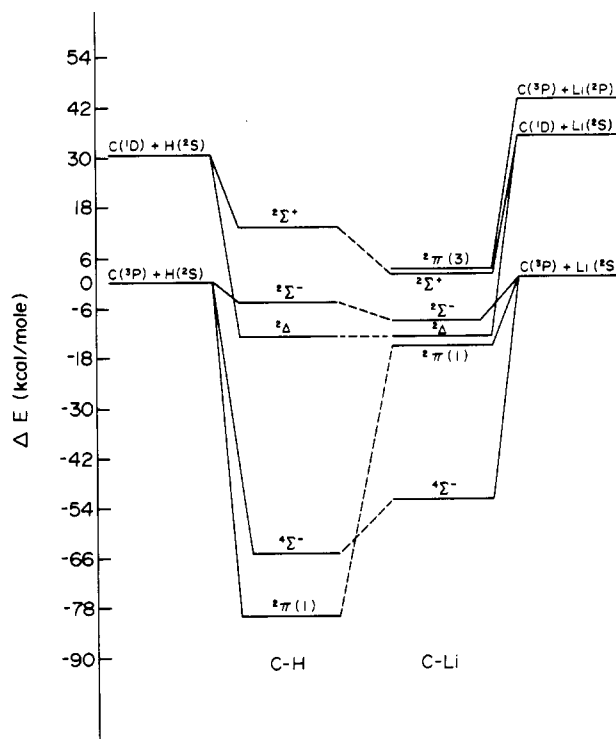

**Figure 1.** Relative energies of the six lowest states of C-Li as predicted by SCF+1+2 calculations and the corresponding energies of C-H as calculated in ref 13.

by S. P. Walch and R. C. Raffanetti to make use of the general contraction scheme. Several of the SCF calculations used the program ALIS.<sup>13</sup>

(13) Rudenberg, K.; Cheung, L. M.; Elbert, S. T. *Int. J. Quantum Chem.* **1979**, *16*, 1069.

Table IV. Comparison of the SCF, CI, and GVB Energies of C-Li in the <sup>4</sup>Σ<sup>-</sup>, <sup>2</sup>Π(1), and <sup>2</sup>Π(3) States

state	R, bohrs	abs energy, hartrees				rel energy, kcal/mol			
		SCF	CI		GVB	CI			GVB
			SCF+1+2	ΔE <sub>Q</sub>		SCF	SCF+1+2	with ΔE <sub>Q</sub>	
<sup>4</sup> Σ <sup>-</sup>	3.70	-45.192 391	-45.285 715	-0.005 05	-45.197 191	0.0	0.0	0.0	0.0
<sup>2</sup> Π(1)	4.00	-45.114 429	-45.226 864	-0.009 67	-45.150 292	48.9	36.9	34.0	29.4
<sup>2</sup> Π(3)	4.00	-45.080 133	-45.197 733	-0.016 59	-45.114 409	70.4	55.2	48.0	51.9

### Energies of the Carbyne C-Li

The electronic configurations corresponding to the six lowest states of C-Li, the dissociation limits of the various states, and the required spin couplings in the Π system are displayed in Table II. Note that we have labeled the Π states according to the number of Π electrons, the regular state <sup>2</sup>Π<sub>r</sub> being <sup>2</sup>Π(1) and the irregular <sup>2</sup>Π<sub>i</sub> being <sup>2</sup>Π(3). Collected in Table III are the energies and bond lengths for each state as predicted by the CI (SCF + singles + doubles) calculations. Also included is the unlinked cluster contribution to the correlation energy (ΔE<sub>Q</sub>) for each state as predicted by Davidson's formula<sup>14</sup>

$$\Delta E_Q = (1 - C_0^2)\Delta E_{SD}$$

where C<sub>0</sub> is the coefficient of the SCF determinant in the CI expansion and ΔE<sub>SD</sub> is the correlation energy recovered in the SCF+1+2 calculation. The SCF+1+2 results are compared in Figure 1 with those calculated for C-H by Lie, Hinze, and Liu.<sup>15</sup> The two most striking differences are the inversion of the order of the <sup>2</sup>Π(1) and <sup>4</sup>Σ<sup>-</sup> states and the presence of the low-lying <sup>2</sup>Π(3) state of C-Li. The corresponding <sup>2</sup>Π(3) state in C-H is of course much higher in energy because of the larger 1s-2p separation in H.

Insight into the electronic structure of C-Li and the differences between C-Li and C-H may be gleaned by comparing the contour maps of the various valence orbitals in the two molecules. Goddard et al.<sup>16,17</sup> have reported the contour maps for the <sup>4</sup>Σ<sup>-</sup> and <sup>2</sup>Π(1) states of C-H, and following this group we write the GVB representations of the <sup>4</sup>Σ<sup>-</sup>, <sup>2</sup>Π(1), and <sup>2</sup>Π(3) states as

$$|^4\Sigma^-\rangle = |(\text{core})(b_r b_l + b_l b_r)\sigma\pi_x\pi_y\alpha\beta\alpha\alpha\rangle$$

$$|^2\Pi_x(1)\rangle = |(\text{core})(b_r b_l + b_l b_r)(l_y l_r + l_r l_y)\alpha\beta\alpha\beta\pi_x\alpha\rangle$$

$$|^2\Pi_x(3)\rangle = |(\text{core})(b_r b_l + b_l b_r)(\pi_{y_r}\pi_{y_l} + \pi_{y_l}\pi_{y_r})\pi_x\alpha\beta\alpha\beta\rangle$$

In these equations b<sub>r</sub>, b<sub>l</sub>, and π<sub>r</sub>, π<sub>l</sub> represent bonding orbitals of σ and π<sub>y</sub> symmetry on the right and left atom, respectively, and l<sub>y</sub>, l<sub>r</sub> represent the lobes of the correlated carbon 2s-like orbital. Solving for these orbitals self-consistently results in the GVB energies which are displayed in Table IV along with the corresponding SCF and CI results. The bond lengths were selected on the basis of the results in Table III. As we can see, the GVB energies track the CI results very well, and an analysis of the more compact GVB functions is certainly relevant.

### Orbital Structure of the C-Li Fragment

While the Hartree-Fock description of the <sup>3</sup>P state of carbon corresponds to the electronic configuration

$$(1s)^2(2s)^2(2p_x)^1(2p_y)^1$$

the GVB description replaces the 2s atomic orbital with two nonorthogonal orbitals l<sub>r</sub>, l<sub>l</sub> of the form<sup>16,17</sup>

$$(2s \pm \lambda 2p_z)(1 + \lambda^2)^{-1/2}$$

where λ = 0.39. These orbitals are called lobe orbitals, and as is evident from Figure 2, they have considerable directional character. Recall that the deviation from unity of the overlap

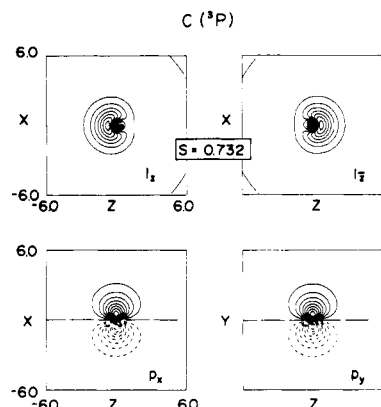
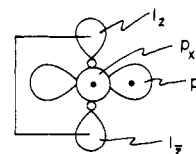

Figure 2. The GVB valence orbitals l<sub>r</sub>, l<sub>l</sub>, p<sub>x</sub>, and p<sub>y</sub> for the <sup>3</sup>P state of C. The plots have uniformly spaced contours with increments of 0.05 au. Positive contours are indicated by solid lines, negative contours are indicated by dotted lines, and nodal planes are indicated by long dashes. The same conventions are used for all plots.

integral between members of a singlet coupled pair is a measure of the inadequacy of the SCF description of that pair. The lobes in <sup>3</sup>P carbon have an overlap of 0.732. The GVB ansatz for the <sup>3</sup>P state of carbon is then

$$1s^2(l_{l_z} + l_{r_z})p_x p_y \alpha\beta\alpha\beta\alpha\alpha$$

with the schematic representation



where the line connecting the two lobe orbitals indicates they are singlet coupled.

When a ground-state lithium atom (represented by ⊙) approaches the C(<sup>3</sup>P), it may do so along a singly occupied p orbital (forming a bond to the p orbital)

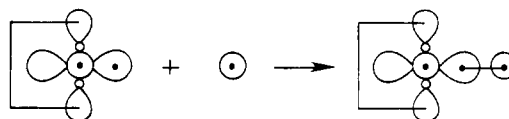

resulting in a <sup>2</sup>Π state. The valence orbitals of C-Li in the <sup>2</sup>Π(1) state are contoured in Figure 3 and are consistent with this picture. The lobes are clearly intact, and the carbon is using a p orbital to form the chemical bond. Note, however, that while in C-H the bond orbital pair consists of a carbon p and a hydrogen s orbital, in C-Li both bond orbitals are substantially carbon p in character. This bond orbital structure, i.e., one compact and localized and one expanded and shared by the two centers, has been emphasized by Goddard et al.<sup>17</sup> to be the signature of a highly polar bond.

The lithium may alternatively approach the carbon along one of the lobe directions resulting in the <sup>4</sup>Σ<sup>-</sup>, <sup>2</sup>Δ, <sup>2</sup>Σ<sup>-</sup> states.

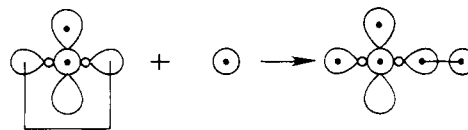

(14) Langhoff, S. R.; Davidson, E. R. *Int. J. Quantum Chem.* **1974**, *8*, 61. Davidson, E. R. "The World of Quantum Chemistry"; Daudel, R., Pullman, B., Eds.; D. Reidel Publishing Co.: Dordrecht, Holland, 1974; pp 17-30.

(15) Lie, G. C.; Hinze, J.; Liu, B. *J. Chem. Phys.* **1972**, *59*, 1872.

(16) Hay, P. J.; Hunt, W. J.; Goddard, W. A., III *J. Am. Chem. Soc.* **1972**, *94*, 8293.

(17) Goddard, W. A., III; Dunning, T. H., Jr.; Hunt, W. J.; Hay, P. J. *Acc. Chem. Res.* **1973**, *6*, 368.

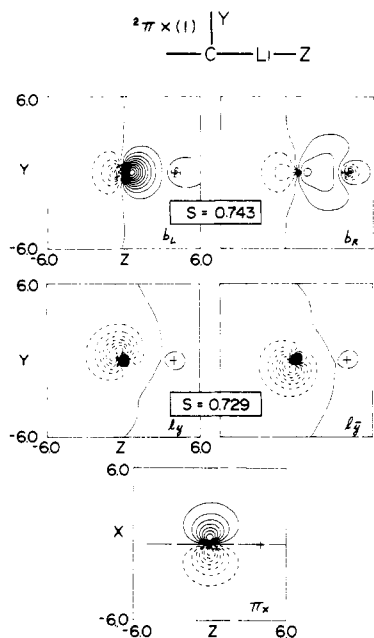

**Figure 3.** The GVB valence orbitals for the  ${}^2\Pi_x(1)$  state of C-Li at an internuclear separation of 4.00 bohrs.

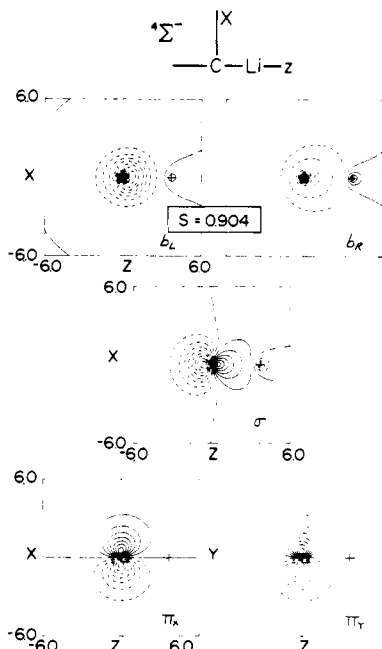

**Figure 4.** The GVB valence orbitals for the  ${}^4\Sigma^-$  state of C-Li at an internuclear separation of 3.70 bohrs.

The contours of the  ${}^4\Sigma^-$  orbitals in Figure 4 are not in keeping with this picture but suggest that considerable electron transfer from Li to C has occurred. This would preclude the use of the carbon  $2p_z$  orbital in the lobe orbitals, forcing them to be  $2s$  like, resulting in the (idealized) picture of a  $C^-({}^4S)$  in the field of a  $Li^+({}^1S)$  which then projects on  $C_{\infty v}$  as a  ${}^4\Sigma^-$  molecular symmetry. The  $2s$ -like character and high overlap between the paired orbitals and the significant  $2p_\sigma$  character of the  $\sigma$  orbital support this view. Once again this is a significant difference from the bonding situation in  $CH({}^4\Sigma^-)$  where the lobes are clearly intact.

Finally, the  ${}^2\Pi(3)$  state is obtained when the Li in a  ${}^2P$  state approaches the carbon along the lobe direction. The contours of the  ${}^2\Pi(3)$  orbitals shown in Figure 5 are in complete agreement with this picture. Interestingly, as we go along the series  ${}^2\Pi(1)$ ,  ${}^4\Sigma^-$ ,  ${}^2\Pi(3)$ , the ratio of the number of  $\pi$  to  $\sigma$  valence electrons goes from  $1/4$  and  $2/3$  to  $3/2$ , while the internuclear separation varies from 4.00 and 3.70 to 3.50 bohrs. When the  $\sigma$  electrons

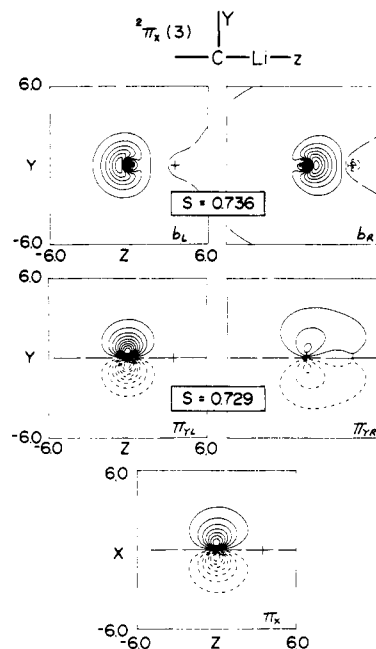
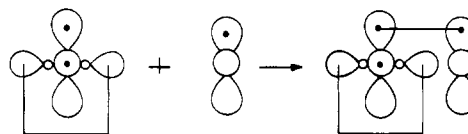

**Figure 5.** The GVB valence orbitals for the  ${}^2\Pi_x(3)$  state of C-Li at an internuclear separation of 3.50 bohrs.

**Table V.** Electronic Configurations of the Seven Lowest States of Linear Symmetric Li-C-Li and Their Dissociation Limits

configuratn	state	dissociatn limit	
		Li	C-Li
$1\sigma_g^2 1\sigma_u^2 2\sigma_g^2 2\sigma_u^2 3\sigma_g^2 3\sigma_u^1 1\pi_u^1$	${}^3\Pi_g(1)$	${}^2S + {}^2\Pi(1)$	
$1\sigma_g^2 1\sigma_u^2 2\sigma_g^2 2\sigma_u^2 3\sigma_g^2 4\sigma_g^1 1\pi_u^1$	${}^3\Pi_u(1)$	${}^2S + {}^2\Pi(1)$	
	${}^3\Sigma_g^-$	${}^2S + {}^4\Sigma^-$	
$1\sigma_g^2 1\sigma_u^2 2\sigma_g^2 2\sigma_u^2 3\sigma_g^2 1\pi_u^2$	${}^1\Delta_g$	${}^2S + {}^2\Delta$	
	${}^1\Sigma_g^+$	${}^2S + {}^2\Sigma^+$	
$1\sigma_g^2 1\sigma_u^2 2\sigma_g^2 2\sigma_u^1 3\sigma_g^2 1\pi_u^3$	${}^{1,3}\Pi_g(3)$	${}^2S + {}^2\Pi(3)$	

are put in the  $\Pi$  system, the  $Li^+$  core can (and does) move closer to the carbon.



The calculated bond strengths do not vary so monotonically. The calculated bond energy in the  ${}^2\Pi(3)$  state is 42 kcal/mol, much larger than the 16 kcal/mol calculated for  ${}^2\Pi(1)$  and similar to the 52 kcal/mol calculated for the  ${}^4\Sigma^-$  state. Keep in mind, however, that the  ${}^2\Pi(3)$  dissociates into  $C({}^3P) + Li({}^2P)$  while both  ${}^2\Pi(1)$  and  ${}^4\Sigma^-$  dissociate to  $C({}^3P) + Li({}^2S)$ .

### The $Li_2C$ Molecule Energetics

The electronic configurations describing the seven lowest states of symmetric linear dilithium carbene are presented in Table V along with the C-Li and Li dissociation products. Collected in Table VI are the energies, bond lengths, and bond angles for each state as calculated with the CI (SCF+1+2) technique. The Davidson correction,  $\Delta E_D$ , is also included. The relative energy as a function of bond angle is shown in Figure 6. While the  ${}^3\Sigma_g^-$ ,  ${}^1\Delta_g$ , and  ${}^1\Sigma_g^+$  states are the expected carbon-centered, "carbene states",<sup>18</sup> the  ${}^3\Pi_g(3)$  and its companion  ${}^1\Pi_g(3)$  state are definitely not. Note that these two states correlate with  $C({}^3P) + Li({}^2S)$  +  $Li({}^1P)$  and the corresponding state in  $CH_2$  would be very high in energy. These unusual states become even more interesting as one bends the molecule, maintaining  $C_{2v}$  symmetry. Except for the  ${}^3A_2$  and  ${}^1A_2$  components of the  ${}^{1,3}\Pi_g(3)$  states all of the

Table VI. Bond Lengths, Bond Angles, and Absolute Energies of the Low-Lying Electronic States of CLi<sub>2</sub> As Predicted by the SCF+1+2 Calculations<sup>a</sup>

state	R, bohrs/θ, deg	abs energy, hartrees		rel energy, kcal/mol	
		SCF+1+2	ΔE <sub>Q</sub>	Δ(SCF+1+2)	with ΔE <sub>Q</sub>
separated ground-state atoms		-52.63392	-0.0041	0.0	0.0
<sup>3</sup> Π <sub>g</sub> (1)	3.978/180	-52.68219	-0.0081	-30.0	-32.8
<sup>1</sup> Π <sub>g</sub> (3)	3.550/180	-52.68470	-0.0111	-31.9	-36.3
<sup>3</sup> Π <sub>u</sub> (1)	3.969/180	-52.69370	-0.0087	-37.5	-40.3
<sup>1</sup> A <sub>2</sub>	3.795/90.3	-52.69785	-0.0156	-40.1	-47.2
<sup>1</sup> Σ <sub>g</sub> <sup>+</sup>	3.690/180	-52.70144	<i>b</i>	-42.4	<i>b</i>
<sup>1</sup> Δ <sub>g</sub>	3.701/180	-52.71866	-0.0107	-53.2	-57.3
<sup>3</sup> Π <sub>g</sub> (3)/ <sup>3</sup> B <sub>2</sub>	3.507/180	-52.72875	-0.0116	-59.5	-64.2
<sup>3</sup> A <sub>2</sub>	3.815/88.1	-52.74218	-0.0215	-67.9	-78.8
<sup>3</sup> Σ <sub>g</sub> <sup>-</sup>	3.717/180	-52.75198	-0.0113	-74.1	-78.6

<sup>a</sup> The absolute energies of the ground state atoms as well as the Davidson correction are also included. <sup>b</sup> The SCF+1+2 calculations for this state were done with the <sup>1</sup>Δ<sub>g</sub>(+) vectors, and we do not have a SCF reference energy with which to calculate the Davidson correction, ΔE<sub>Q</sub>.

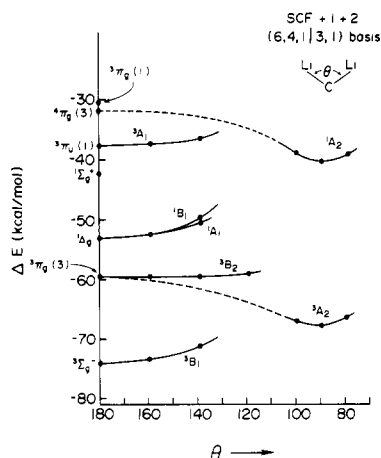

Figure 6. Angular dependence of the energy (relative to the separated ground state atoms) of various low-lying states of Li<sub>2</sub>C as calculated with the SCF+1+2 technique.

states listed remain linear and these A<sub>2</sub> states both have equilibrium angles around 90°.

From Table VI and Figure 6 we see that there are three triplet states (<sup>3</sup>Σ<sub>g</sub><sup>-</sup>, <sup>3</sup>A<sub>2</sub>, and <sup>3</sup>B<sub>2</sub>) below the first singlet (<sup>1</sup>Δ<sub>g</sub>). The two lowest triplets, <sup>3</sup>Σ<sub>g</sub><sup>-</sup> and <sup>3</sup>A<sub>2</sub>, have very different geometries and at the SCF+1+2 level are separated by 6.2 kcal/mol (14.0 kcal/mol at the SCF level). Correcting these variational CI energies for the contributions of higher excitations using Davidson's formula results in the <sup>3</sup>A<sub>2</sub> dropping below the <sup>3</sup>Σ<sub>g</sub><sup>-</sup> by 0.2 kcal/mol. Our calculations clearly do not permit us to say which is the ground state, simply that the two states are very nearly degenerate. In addition, from Figure 7 we see that all three triplets are bound with respect to the lowest dissociation channel, C-Li(<sup>4</sup>Σ<sup>-</sup>) and Li(<sup>2</sup>S). The energy difference between the minima in the Renner-Teller pair (<sup>3</sup>A<sub>2</sub> - <sup>3</sup>B<sub>2</sub>) is calculated to be 8.4 kcal/mol at the SCF+1+2 level and 14.6 kcal/mol when corrected for higher excitations. The 21.3 kcal/mol singlet-triplet separation (<sup>1</sup>Δ<sub>g</sub> - <sup>3</sup>Σ<sub>g</sub><sup>-</sup>) is much larger than in CH<sub>2</sub><sup>19</sup> and is in the direction expected for a substituent more electropositive<sup>3a</sup> than H.

### The Bonding in the Three Lowest Triplet States of Li<sub>2</sub>C

As with C-Li, it is most instructive to construct GVB representations of the states of interest and examine the various orbitals. We take the GVB representation of the <sup>3</sup>Σ<sub>g</sub><sup>-</sup> states as

$$|^3\Sigma_g^-\rangle = |(\text{core})(\phi_r\psi_r + \psi_r\phi_r)(\phi_l\psi_l + \psi_l\phi_l)\pi_{ux}\pi_{uy}\alpha\beta\alpha\beta\rangle$$

where  $\phi_r$ ,  $\psi_r$  and  $\phi_l$ ,  $\psi_l$  are the  $\sigma$  orbitals representing the bonds to the right and left of the carbon atom. These  $\sigma$  orbitals are, of course, singlet coupled, the multiplicity being carried by the  $\pi_{ux}$  and  $\pi_{uy}$  orbitals.

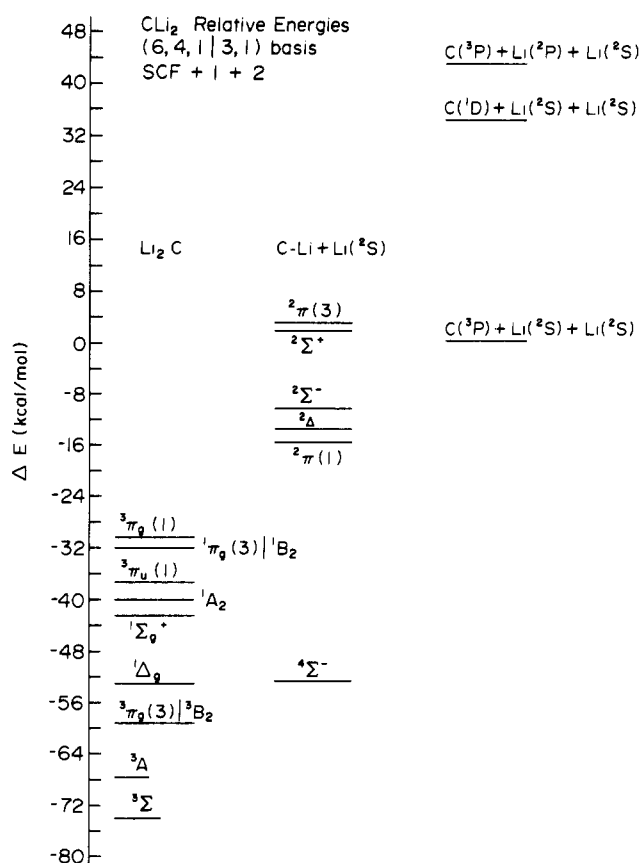

Figure 7. The calculated energy (SCF+1+2) of Li<sub>2</sub>C, C-Li + Li, and C + 2Li relative to the ground-state atoms.

The <sup>3</sup>Π<sub>g</sub>(3) state is obtained from the <sup>3</sup>Σ<sub>g</sub><sup>-</sup> state by promoting and electron from a  $\sigma$  to a  $\pi$  orbital, resulting in three valence electrons in the  $\sigma$  and three in the  $\Pi$  systems. A GVB ansatz consistent with this is

$$|^3\Pi_g(3)\rangle = |(\text{core})(\phi\psi + \psi\phi)(\pi_{xa}\pi_{xb} + \pi_{xb}\pi_{xa})\sigma_u\pi_{uy}\alpha\alpha\rangle$$

where  $\phi$  and  $\psi$  as well as  $\pi_{xa}$  and  $\pi_{xb}$  are singlet coupled and  $\sigma_u$  and  $\pi_{uy}$  are triplet coupled. The <sup>3</sup>A<sub>2</sub> state is obtained from the <sup>3</sup>Π<sub>g</sub>(3) by bending in the  $xz$  plane and maintaining C<sub>2v</sub> symmetry. In this case  $\sigma_u$  becomes b<sub>2</sub>,  $\pi_{uy}$  is b<sub>1</sub>,  $\phi$  and  $\psi$  are linear combinations of a<sub>1</sub> and b<sub>2</sub>, and  $\pi_{xa}$  and  $\pi_{xb}$  are both of a<sub>1</sub> symmetry. The orbitals in the above expressions were solved for self-consistently at the selected geometries indicated in Table VII. These geometries are very close to the SCF+1+2 equilibrium geometries for the state in question. As can be seen from Table VII, the relative energies track the CI energies very well and we are again confident that the essential physics is in the GVB formulation. The contour maps of the <sup>3</sup>Σ<sub>g</sub><sup>-</sup> orbitals are shown in Figure 8. The

(19) Saxe, P.; Schaefer, H. F., III; Handy, N. C. *J. Phys. Chem.* **1981**, *85*, 745.

Table VII. Comparison of the SCF, CI, and GVB Energies of  $\text{Li}_2\text{C}$  in the  ${}^3\Sigma_g^-$ ,  ${}^3A_2$ , and  ${}^3\Pi_g(3)$  States

state	<i>R</i> , bohrs/ $\theta$ , deg	SCF	abs energy, hartrees			rel, energy, kcal/mol			
			CI			GVB	CI		
			SCF+1+2	$\Delta E_Q$	SCF		SCF+1+2	with $\Delta E_Q$	GVB
${}^3\Sigma_g^-$	3.70/180	-52.624 209	-52.751 961	-0.0113	-52.649 012	0.0	0.0	0.0	0.0
${}^3A_2$	3.80/90	-52.600 633	-52.742 143	-0.0215	-52.642 759	14.8	6.2	-0.2	3.9
${}^3\Pi_g(3)$	3.50/180	-52.599 287	-52.728 743	-0.0116	-52.621 421	15.6	14.6	14.4	17.3

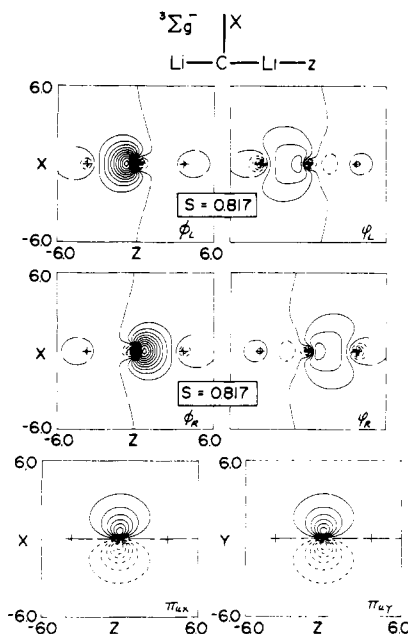
Figure 8. The GVB valence orbitals of the  ${}^3\Sigma_g^-$  state of  $\text{Li}_2\text{C}$  at a C-Li bond length of 3.70 bohrs.

bond orbitals  $\phi_1$ ,  $\psi_1$  and  $\phi_r$ ,  $\psi_r$  have the characteristic ionic appearance similar to the bond orbitals of C-Li in the  ${}^2\Pi(1)$  state (Figure 3). The contour maps of the  ${}^3\Pi_g(3)$  orbitals (Figure 9) and the high overlap of the  $\phi$  and  $\psi$  orbitals suggest that the carbon 2s-like orbital is essentially doubly occupied and that the third  $\sigma$  electron is in a carbon  $2p_\sigma$  orbital with some lithium contribution. The contours of the  $\pi$  orbitals are similar to those of the parent  ${}^2\Pi(3)$  state (Figure 5) and indicate considerable Li participation in the  $\Pi$  system. Indeed, there seem to be three electrons involved in the bonding and two are in the  $\Pi$  system.

When the  ${}^3\Pi_g(3)$  state is bent in the  $xz$  plane, the  ${}^3A_2$  state obtains and the contours of the GVB orbitals at a geometry close to the SCF+1+2 geometry are shown in Figure 10. These orbitals have an obvious relation to those of the linear configuration in spite of the dramatic change in the optimized geometry (3.50 au at  $180^\circ$  to 3.80 au at  $90^\circ$ ). This highly bent geometry corresponds to a  $\text{Li}_2$  separation of 5.374 bohrs and a C-Li<sub>2</sub> separation of 2.687 bohrs. The  $\text{Li}_2$  separation is between the calculated<sup>20</sup>  $\text{Li}_2^+$  separation of 5.94 bohrs and the experimental<sup>21</sup>  $\text{Li}_2$  separation of 5.047 bohrs. This  $\text{Li}_2$  separation and the contours in Figure 10 suggest that the  ${}^3A_2$  state may be thought of as a C atom bonding with an empty  $p_\sigma$  orbital in a  $\sigma$  (edge on) fashion to the  $2\sigma_g$  orbital of  $\text{Li}_2$ . This suggested bonding mode (with  $\text{N}^+$  and  $\text{H}_2$  instead of C and  $\text{Li}_2$ ) has been invoked previously by Dewar<sup>22</sup> to rationalize a calculated<sup>23</sup> highly bent structure for a  ${}^3A_2$  state of  $\text{NH}_2^+$ . The unique point about the present  ${}^3A_2$  state of  $\text{Li}_2\text{C}$  is that it may be the ground state while in  $\text{NH}_2^+$  the highly bent structure is some 60 kcal/mol above<sup>23,24</sup> the ground state.

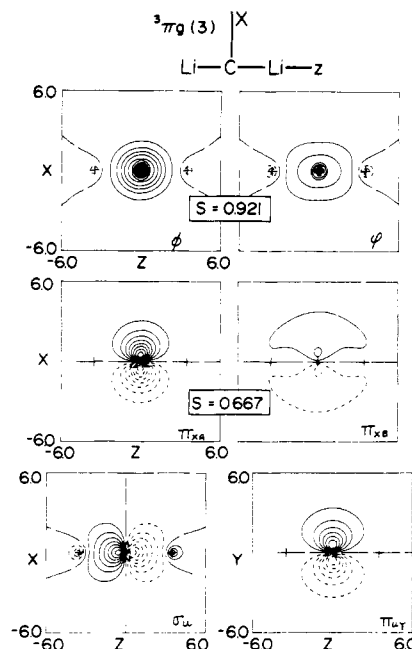
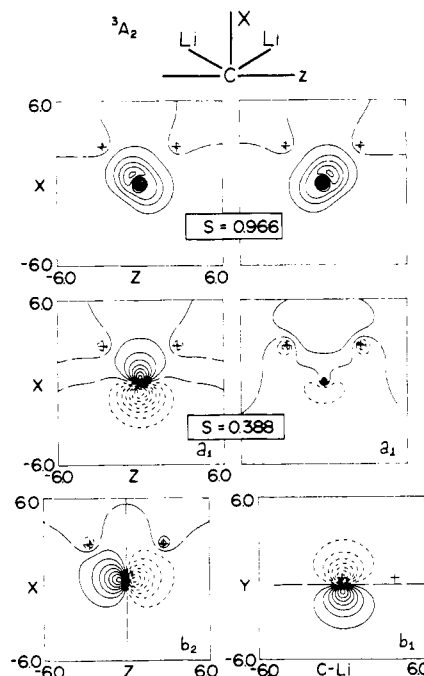
(20) Henderson, G. A.; Zemke, W. T.; Wahl, A. C. *J. Chem. Phys.* **1973**, *58*, 2654.(21) Loomis, F. W.; Nusbaum, R. E. *Phys. Rev.* **1931**, *38*, 1447.(22) Dewar, M. J. S. *Faraday Discuss. Chem. Soc.* **1977**, *62*, 138.(23) Bender, C. F.; Meadows, J. H.; Schaefer, H. F., III *Faraday Discuss. Chem. Soc.* **1977**, *62*, 59.(24) Hirst, D. M. *Faraday Disc. Chem. Soc.* **1977**, *62*, 138.Figure 9. The GVB valence orbitals of the  ${}^3\Pi_g(3)$  state of  $\text{Li}_2\text{C}$  at a C-Li bond length of 3.50 bohrs.Figure 10. The GVB valence orbitals of the  ${}^3A_2$  state of  $\text{Li}_2\text{C}$  at a bond length of 3.80 bohrs and bond angle of  $90^\circ$ .

### Concluding Remarks

This work permits several conclusions and a few speculations. On the conclusion side we note that the ground state of C-Li is a  ${}^4\Sigma$  state, the lowest  ${}^2\Pi(1)$  state being approximately 34 kcal/mol higher in energy. This should be contrasted to C-H in which the

$^2\Pi(1)$  state is 18 kcal/mol below<sup>25</sup> the  $^4\Sigma^-$ . In addition, the reaction

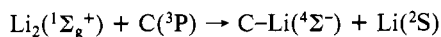

is exothermic by at least 27 kcal/mol, while the corresponding  $\text{H}_2$  reaction

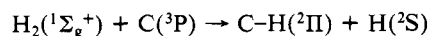

is endothermic<sup>26</sup> by 23 kcal/mol.

For  $\text{Li}_2\text{C}$  we have found three bound triplet states well below the first singlet. While two of these triplets, the  $^3\Sigma_g^-$  and  $^3A_2$  have very different geometries, they have essentially identical (at our level of accuracy) energies. We estimate that both are bound relative to  $\text{C}(^3\text{P}) + \text{Li}_2(^1\Sigma_g^+)$  by at least 53 kcal/mol. If one reduces the symmetry from  $C_{2v}$  to  $C_s$ , these two triplets share the  $^3A'$  symmetry and would suffer an avoided crossing. This avoided crossing will have a significant effect on the dynamics of the reaction of ground state C and  $\text{Li}_2$ .

Both the ground state of C-Li and the low-lying  $^3A_2$  state of  $\text{Li}_2\text{C}$  are characterized by a donation of electrons from Li or  $\text{Li}_2$  to an "empty"  $p_\sigma$  orbital on C. Schematically

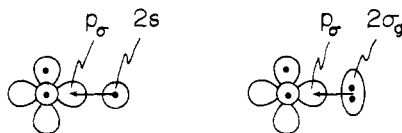

completely analogous to the  $\text{N}^+ + \text{H}_2$  case discussed by Dewar.<sup>22</sup> This observation prompts the speculation that one might fruitfully consider the recently predicted<sup>4,6</sup> dilithiomethane structure as carbenoids resulting from the donation of electrons from the bonding orbital on  $\text{Li}_2$  into a formally empty  $\sigma$  orbital on  $\text{CH}_2$ . For example, the planar  $^1A_1$  state would have the form

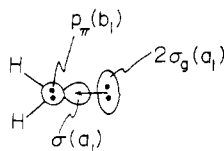

(25) Kasdan, A.; Herbst, E.; Lineberger, W. C. *Chem. Phys. Lett.* **1975**, *31*, 78.

(26) Shevlin, P. B. "Advances in Reactive Intermediates"; Abramovitch, R. A., Ed.; Plenum Press: New York, 1980; Vol. 1, p 9.

Our calculations on  $\text{CLi}_2$  suggest that in this mode of bonding the  $\text{Li}_2$  separation would be between 5 and 6 bohr and the  $\text{Li}_2$  end of the molecule positive relative to the  $\text{CH}_2$  end. The optimized SCF structure of Ladig and Schaefer<sup>6</sup> has the  $\text{Li}_2\text{C}$  angle as  $101.7^\circ$  and  $R(\text{C-Li}) = 3.485$  bohr (corresponding to a  $\text{Li}_2$  separation of 5.40 bohrs and a C- $\text{Li}_2$  separation of 2.20 bohrs), with a dipole moment of +4.85 D. As we rotate the  $\text{Li}_2$  group  $90^\circ$  about the  $C_2$  axis to form the "tetrahedral" isomer, we lose the stability due to the delocalization of the carbon  $p_\pi$  electrons into the Li  $p_\pi$  orbitals (a Li-Li bonding interaction), but we gain the ability to delocalize these electrons into the  $\text{Li}_2 \sigma_u^*$  orbital. This should result in an increased  $\text{Li}_2$  separation and  $\text{LS}^6$  calculated 6.49 bohrs which is an increase of 1.09 bohrs over the planar separation.

We can imagine the planar triplet being formed from the planar singlet by exciting an electron from the  $2p_\pi$  on carbon to a primarily  $\sigma_g$  orbital ( $a_1$  in  $C_{2v}$ ) on  $\text{Li}_2$ . Qualitatively, this  $\sigma_g$  orbital would be the out of phase combination of the methylene  $\sigma$  and  $\text{Li}_2 2\sigma_g$  orbitals. When this orbital is occupied, one anticipates that, relative to the planar singlet, the  $\text{Li}_2$  separation would decrease, the C- $\text{Li}_2$  separation would increase, and the dipole moment be negative on the  $\text{Li}_2$  side of the molecule.  $\text{LS}^6$  calculate a  $\text{Li}_2$  separation of 4.684 bohrs (a decrease of 0.721 bohr), a C- $\text{Li}_2$  separation of 3.131 bohrs (an increase of 0.931 bohr), and a dipole moment of -1.22 D (planar  $^1A_1$  was +4.85 D). As with the planar singlet, rotating the  $\text{Li}_2$  group in the  $^3B_1$  state by  $90^\circ$  about the  $C_2$  axis would destroy the delocalization of the carbon  $2p_\pi$  orbital into the  $\text{Li}_2 \pi$  orbitals but will allow the delocalization of this  $2p_\pi$  orbital into the  $\text{Li}_2 \sigma_u^*$  orbital. Because there is only one electron in this  $\pi$  orbital and the  $\text{Li}_2$  is rather distant ( $>3$  bohrs) from the carbon, this delocalization would increase the  $\text{Li}_2$  separation only slightly. The calculated<sup>6</sup> increase is 0.066 bohrs.

While the ease with which this very simple model accounts qualitatively for the structural changes in the dilithiomethane is satisfying, the speculations should, of course, be checked with detailed calculations.

**Acknowledgment.** J.F.H. has benefited from the stimulating environment provided by the members of the Theoretical Chemistry Group at Argonne. The willingness of B. Botch, L. Harding, and T. Dunning, Jr., to advise us on the use of the various codes has been crucial to the completion of this study.

**Registry No.** LiC, 81572-61-4;  $\text{Li}_2\text{C}$ , 72023-94-0.

## Electron Transfer to Complex Ligands. Radical Anions and Organomagnesium Radical Complexes of 2,2'-Bipyridines and 1,10-Phenanthrolines

Wolfgang Kaim

Contribution from the Chemistry Department, J. W. Goethe Universitaet, Niederurseler Hang, D-6000 Frankfurt/Main, West Germany. Received April 24, 1981

**Abstract:** The bidentate complex ligands 2,2'-bipyridine (**1**), 4,4'-dimethyl-2,2'-bipyridine (**2**), 1,10-phenanthroline (**3**), and 4,7-dimethyl-1,10-phenanthroline (**4**) have been reduced to radical anions by potassium metal and to organomagnesium radical complexes in a single electron transfer (SET) reaction of diphenylmagnesium. Well-resolved ESR spectra were obtained that could be analyzed on the basis of HMO calculations. In the case of the 1,10-phenanthrolines there are two low unoccupied molecular orbitals available to accommodate the additional electron; a comparison of the spin distributions demonstrates that, in contrast to earlier assumptions, it is the  $5b_1$  orbital that is singly occupied. This result helps to explain the similar properties of corresponding 2,2'-bipyridine and 1,10-phenanthroline metal complexes.

2,2'-Bipyridine (bpy) and 1,10-phenanthroline (phen) have been widely used as "classical" complex ligands for metal ions and

inorganic or organometallic fragments.<sup>1-3</sup> Apart from their good  $\sigma$ -donor complexing properties due to the bidentate coordination,